

### CRITICAL CARE TRANSPORT TROLLEY CRASH TESTED TO BS EN 1789:2020

## FULL RAIL OPTION

With the option of a full equipment rail, a half equipment rail, a lower monitor position (depending on the model of ventilator used) and option to extend the upper frame the trolley provides a versatile canvas to build the system on. Designed in accordance with BS EN 1789, BS EN 1865-3, EN 13976 2 and EN ISO 19054 and following ISO9001 quality management system.

All Levana trolleys are **fully crash tested** in accordance with BS EN 1789 and independently witnessed by the VCA. Comes fully equipped with equipment holders, fully crash tested in accordance with BS EN 1789 and independently witnessed by the VCA.

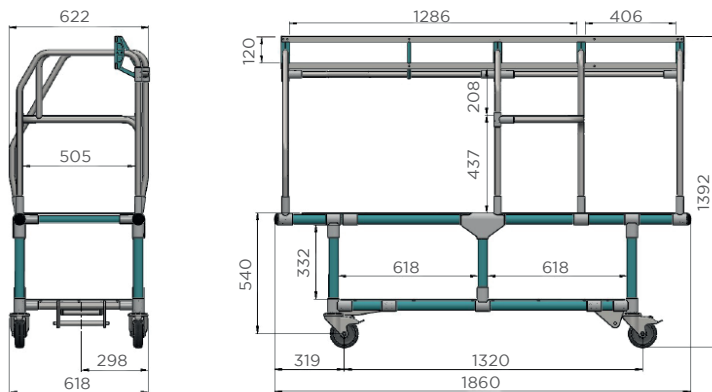
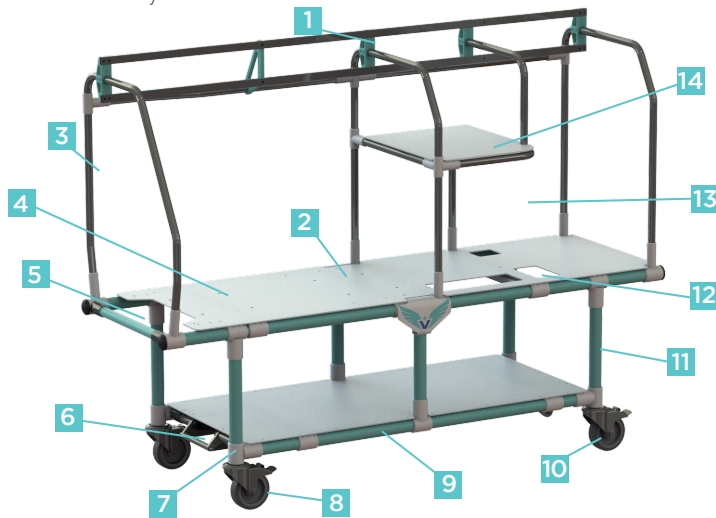

### FEATURES

- 1 Equipment rail meeting EN ISO 19054
- 2 Data plate for identification
- 3 Push bars
- 4 Hole options allow for attachment of a range of incubators
- 5 Access to cylinders on bottom shelf
- 6 Two part lock attachment brackets with adjustable wedge at head end to allow for subtle tolerances in ambulance
- 7 Winch points for ramp loading ambulances
- 8 125mm Diameter total lock castor wheels
- 9 Scratch resistant powder coat finish
- 10 Stem fitting castor wheels for easy replacement
- 11 Constructed of high strength and lightweight materials
- 12 Access holes to lower shelf
- 13 Shape of frame allows for hoses and cables from ventilators
- 14 Monitor frame can be set to a range of heights

THE FOREFRONT OF MEDICAL TRANSPORTATION



0121 828 8751

[info@vanguard-medical.co.uk](mailto:info@vanguard-medical.co.uk)

[www.vanguard-medical.co.uk](http://www.vanguard-medical.co.uk)

### CRITICAL CARE TRANSPORT TROLLEY CRASH TESTED TO BS EN 1789:2020

## HALF RAIL OPTION

With the option of a full equipment rail, a half equipment rail, a lower monitor position (depending on the model of ventilator used) and option to extend the upper frame the trolley provides a versatile canvas to build the system on. Designed in accordance with BS EN 1789, BS EN 1865-3, EN 13976 2 and EN ISO 19054 and following ISO9001 quality management system.

All Levana trolleys are **fully crash tested** in accordance with BS EN 1789 and independently witnessed by the VCA. Comes fully equipped with equipment holders, fully crash tested in accordance with BS EN 1789 and independently witnessed by the VCA.

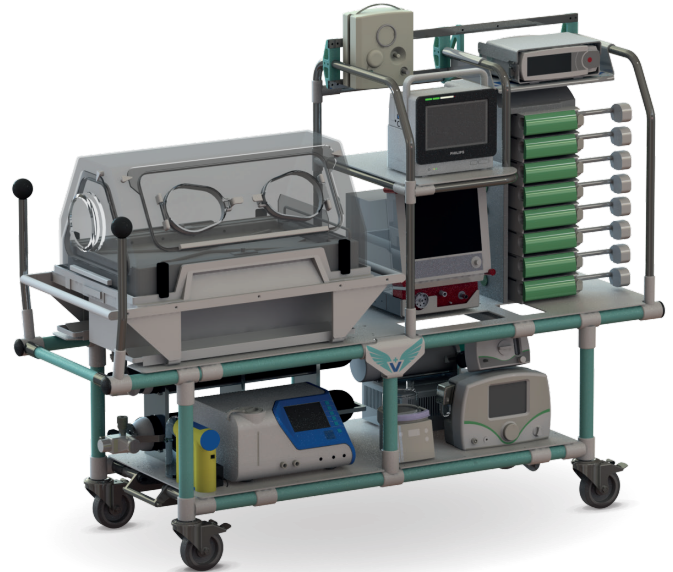

### FEATURES

- 1 Equipment rail meeting EN ISO 19054
- 2 Data plate for identification
- 3 Push bars
- 4 Hole options allow for attachment of a range of incubators
- 5 Access to cylinders on bottom shelf
- 6 Two part lock attachment brackets with adjustable wedge at head end to allow for subtle tolerances in ambulance
- 7 Winch points for ramp loading ambulances
- 8 125mm Diameter total lock castor wheels
- 9 Scratch resistant powder coat finish
- 10 Stem fitting castor wheels for easy replacement
- 11 Constructed of high strength and lightweight materials
- 12 Access holes to lower shelf
- 13 Shape of frame allows for hoses and cables from ventilators
- 14 Monitor frame can be set to a range of heights

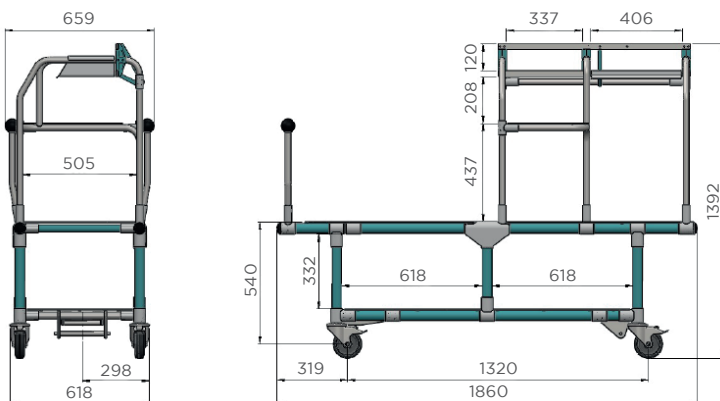

THE FOREFRONT OF MEDICAL TRANSPORTATION



0121 828 8751

[info@vanguard-medical.co.uk](mailto:info@vanguard-medical.co.uk)

[www.vanguard-medical.co.uk](http://www.vanguard-medical.co.uk)